

SITE LIFTING

現場吊裝



Multipurpose and portable winch 多功能便攜式捲揚機

Capacity 300 kg

容量300KG

**Its motor:
your own hand drill !**

**它的馬達：
你自己的手提電鑽！**

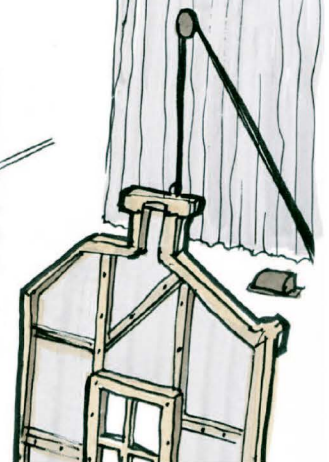
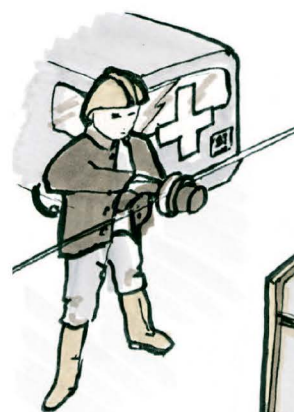
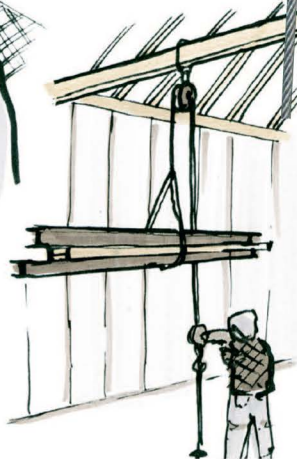
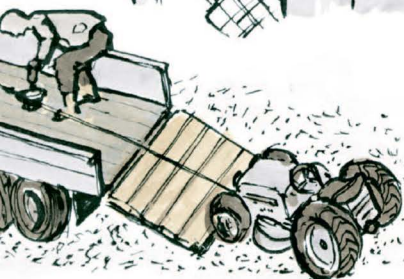
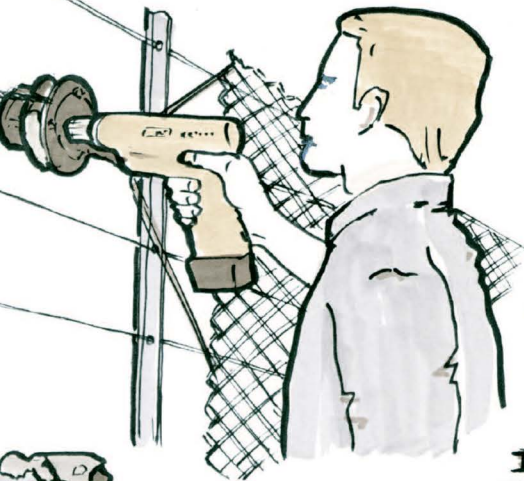

Technical data and dimensions 技術參數和尺寸

Use: lifting

- Light work: maintenance, upkeep, repairs, fitting, installations, small sites, agriculture, first aid, etc.
- Leisure: mechanised gardening, quads, DiY, etc.

用途：吊裝

- 輕的工作：維修，保養，修護，配件，安裝，小現場，農業，優先幫助等
- 休閒：機械化園藝，四邊形，DIY(自己動手做)等。

Technical properties:

- Can be used with all screwdrivers, cordless or not
- Easy to set up: suspension hook
- Small size
- Light
- Work in all positions

技術特性：

- 可以和所有電動螺絲起子一齊使用，無線或有線
- 易於設置：掛鉤懸吊
- 小尺寸
- 輕的
- 在所有位置工作

- 300 kg capacity
- Unlimited cable length in traction, 50 m for lifting (beyond 12 m, loss of 10% of lifting force per 10 m section)
- Automatic load maintenance system (patented self-braking brake reducer)
- Weight: 7.5 kg (with 12 m cable and hook)
- Supplied as standard with 12 m cable (aviation type \varnothing 4.76 mm galvanised steel cable)

- 荷重300公斤
- 在牽引可有無限制鋼索長度，50米起吊高（專利自我制動剎車減速機）
- 自動負載維護系統（專利自製制動剎車減速）
- 重量：7.5KG（含12M鋼索和鉤）
- 提供標準配備含12M鋼索（航空型 Φ 4.76mm鍍鋅鋼絞線）

- **Complete kit:** case, winch, drill, charger, sling and shackles, available.

- **完整的工具包：**外盒，捲揚機，電鑽，充電器，吊具和卸克，可用的

Demonstration set out
展示陳列架

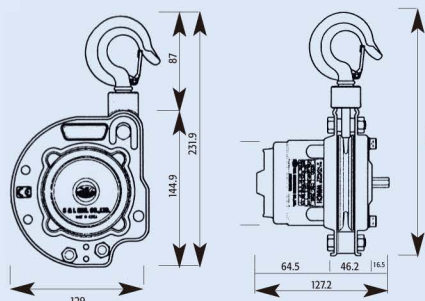

Haulage capacity on wheels	6°	1500 kg
	12°	975 kg
	16°	825 kg
	27°	585 kg
	35°	450 kg

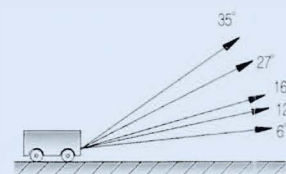

Type	Capacity kg	Lifting height m	Rope dia. m	Weight (with 12 m cable and hook) kg
	300	unlimited	4.76	7.5

a complete range of lifting equipment

一家完整系列的起重設備

