

實用工具接地捲線器

Utility Grounding Reels

TRUCK GROUNDING REELS

卡車接地捲線器

- Easy cable pay-out.
- Quick and convenient rewind gets you back in service fast.
- Heavy-duty steel construction stands up to demanding field use.
- Direct access to lube rotary ground device.
- Serviceable pawl and pin assembly.

- Independently tested to 43 kA for 30 cycles.*
- Bolt-down design.
- Manual or Automatic Spring Rewind available.
- Helps meet OSHA requirements for vehicle grounding.**
- Supplied with or without optional cable & clamp.

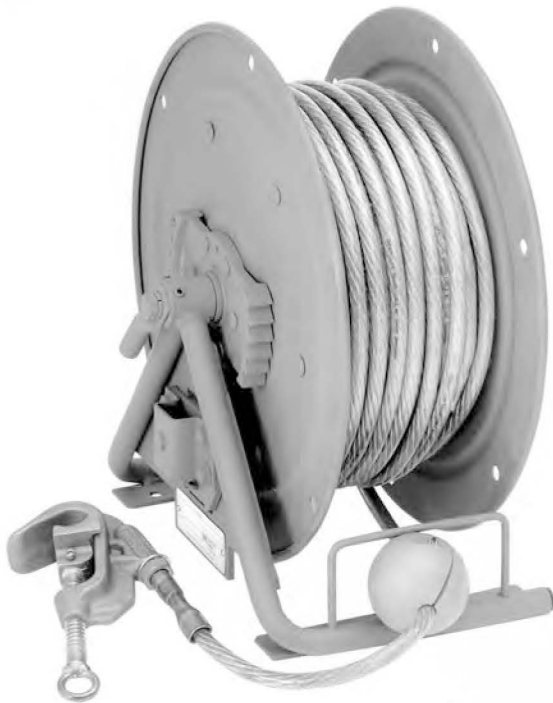

型號SGCR 10-17-19彈簧捲取
Model SGCR 10-17-19
Spring Rewind

Standard Configuration Shown
with optional cable & clamp



型號GCR 10-17-19手動捲取
Model GCR 10-17-19
Manual Rewind

Standard Configuration Shown

使用上：

- 工程車輛
- 多功能車

For use on:

- **Construction Vehicles**
- **Maintenance Vehicles**

- 維修車輛
- 救援和危險品車輛

- **Utility Vehicles**
- **Rescue & HazMat Vehicles**

* Although Hannay SGCR and GCR series grounding reels are rated to 43 kA for 30 cycles (the maximum fault current rating for 4/0 cable), the size and spring pull force of the reel effectively limits use of these reels to 2/0 cable and smaller. 2/0 cable has a maximum fault current rating of 27 kA. Please refer to ASTM 855-90 (Standard Specification for Temporary Grounding Systems) for more information.

** OSHA Subpart V, Section 1926.952 requires grounding of vehicles working near energized lines or equipment. Hannay grounding reels help meet this requirement and encourage crew compliance by providing a simple, efficient method of handling heavy grounding cable.

SGCR/GCR/GC

型號 SGCR 10-17-19 彈簧捲取接地捲線器

Model SGCR 10-17-19

Spring Rewind Grounding Reel

- Fast, convenient automatic spring rewind.
- A ratchet mechanism locks the reel.
- Built-in cable hoop.
- Internal rotary device.
- Parts list drawing, request ISO 95.

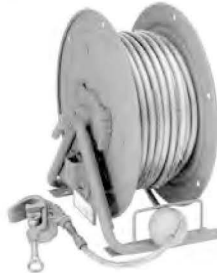

Standard Configuration
Shown with optional
cable & clamp

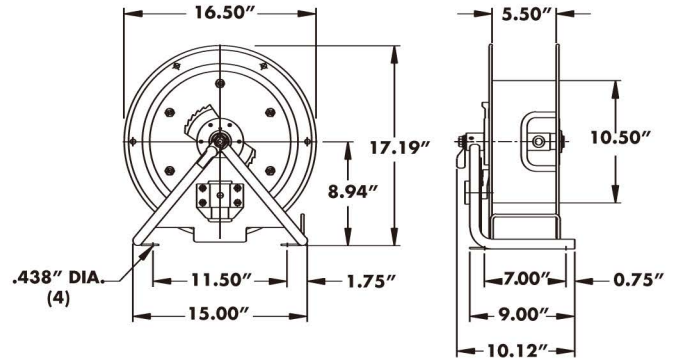

型號 GCR 10-17-19 手動捲取接地捲線器

Model GCR 10-17-19

Manual Rewind Grounding Reel

- Offers manual rewind with a hand crank permanently attached to the disc.
- An internal rotary device.



Standard Configuration
Shown

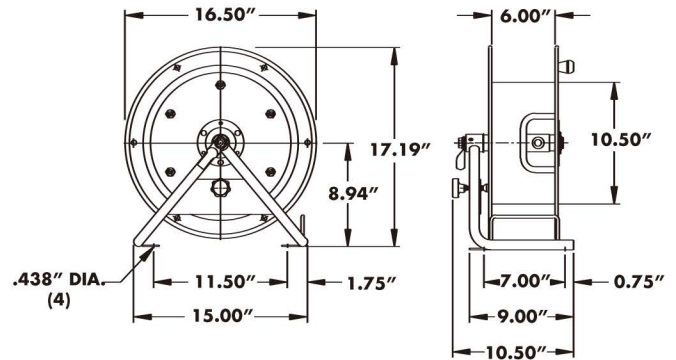

型號 GC 10-17-19 手動儲存接地捲線器 (未顯示)

Model GC 10-17-19

Manual Storage Reel (Not Shown)

- "STORAGE ONLY"
- Manual rewind with a hand crank permanently attached to the disc.

Model Number	Cable Capacity of Reel feet m.			Approx. Weight lb. kg	
	Gauge of Conductor			NET (less cable)	SHIP (less cable)
	#2	1/0	2/0		
	0.50 O.D. (in) 13 O.D. (mm)	0.63 O.D. (in) 16 O.D. (mm)	0.66 O.D. (in) 17 O.D. (mm)		
SGCR 10-17-19	75 22.9	75 22.9	65 19.8	43 20	52 24
GCR 10-17-19	150 45.7	90 27.4	90 27.4	30 14	36 16
GC 10-17-19	150 45.7	90 27.4	90 27.4	28 13	34 15

***Note:** 注意

If shipping reel with cable, add 16 lbs for packaging, plus weight of cable.

Cable Weights: #2 gauge = .28 lb/ft
1/0 gauge = .43 lb/ft
2/0 gauge = .52 lb/ft

訂購 (列出指定的所有項目)

To Order (Specify all items listed):

- Cable gauge, length, and O.D.
- Complete model number

Reels can be shipped as a parcel package (via FedEx or UPS ground).