

10CBW

10CBW型配重平衡手動絞盤堆高機

能力1000磅(454公斤)

10CBW

- 1000 lb. Capacity 能力1000磅(454公斤)
- Counterbalanced 配重平衡
- Manual Winch with Brake 手動絞盤附剎車

OPTIONAL ACCESSORIES 可選配件

- Polyurethane Wheels - Direct Bolt-On 聚氨酯輪子 - 直接用螺栓固定
- Steel Wheels - Direct Bolt-On 鋼製輪轂 - 直接用螺栓固定
- Swivel Boom - Limited Swing Motion Design 旋轉臂 - 有限的擺動運動設計
- Available in Stainless Steel Construction 提供不銹鋼結構

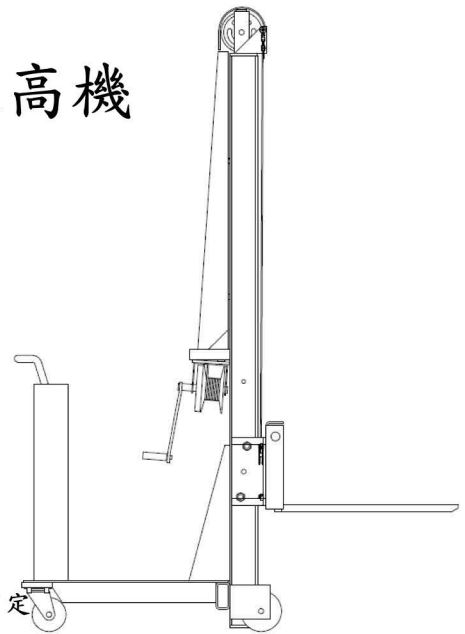

Meets ASME PALD standards
for shop cranes.

Conforms to ANSI Z535 standards.

符合ASME PALD標準作為工廠吊車
依據ANSI Z535標準

Standard Features

標準特性

- Meets Ruger's structural engineering standards for 150% of rated lifting capacity
- Counterbalanced units are built to exceed 150% stability factor
- Double action manual hand pump operation
- Built-in hydraulic overload relief valve
- Needle type release valve permits pin-point control over lowering and holding of the heaviest or lightest loads
- Adjustable built-in telescopic boom
- Steel wheels with sleeve bearings
- Swivel hook with safety latch
- Steel construction & standard Ruger blue paint

10CBW型配重平衡手動絞盤堆高機

能力1000磅(454公斤)

MODEL: 10CBW

Load Capacity 1000 lbs
承載能力 1000磅(454公斤)

Figure 1 圖一

