

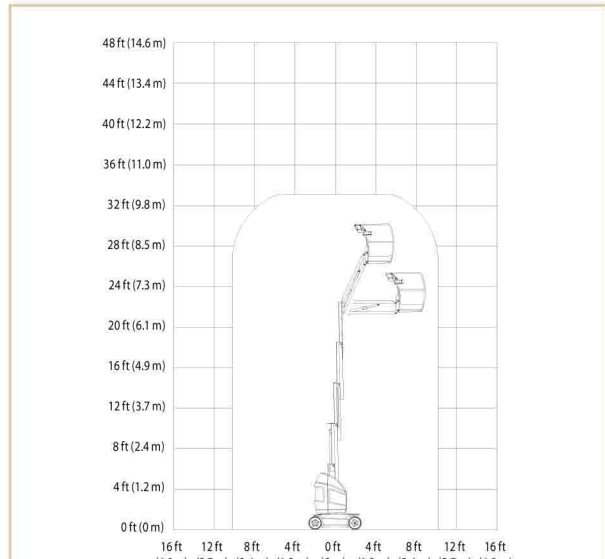

MLJ26EX 防爆型桅杆升降平台
MLJ26EX EXPLOSION PROOF MAST LIFT

規格	英制	公制
SPECIFICATIONS	US	METRIC
Platform Height 平台高度	26 ft 6 in	8.05 m
Horizontal Outreach 水平延伸	8 ft 8 in	2.64 m
Up and Over Height	22 ft	6.71 m
Swing 擺幅	360° Non-continuous	
Platform Capacity 平台能力	500 lb	227 kg
Platform Size 平台尺寸	27.5x35.4 in	70 x 90 cm
Stowed Height 存放高度	6 ft 6.5 in	1.99 m
Stowed Width 存放寬度	39 in	99 cm
Stowed Length 存放長度	11 ft 1 in	3.38 m
Tailswing 尾部擺幅	4 in	10 cm
Wheelbase 軸距	3 ft 11 in	1.2 m
Weight 重量	6,834 lb	3,100 kg
Ground Bearing Pressure	256 psi	18.0 kg/cm ²
Ground Clearance 離地間隙	3 in	8 cm
Battery 電池	24V, 240 amp-hr	
Battery Charger-Output	25 amps	
Brakes 制動器	Spring Applied	

*Specifications Subject to Change Without Prior Notice



Range Diagram 範圍圖

MLJ26EX

- **Explosion Proof** 防爆
- **Class I, Division 1, Group D** I級, 1區, D組

STANDARD EQUIPMENT 標準設備

- 360° Non-continuous Swing
- 5° Tilt Indicator Light
- Battery Condition Indicator
- Hourmeter
- Lifting Eyes
- Tie-down Lugs

OPTIONS 選項

- ½ in. Airline to Platform
- Motion Alarm



MLJ33EX 防爆型桅杆升降平台

MLJ33EX EXPLOSION PROOF MAST LIFT

規格	英制	公制
SPECIFICATIONS	US	METRIC
Platform Height 平台高度	32 ft 9 in	9.98 m
Horizontal Outreach	14 ft 6 in	4.42 m
Up and Over Height	23 ft 6 in	7.16 m
Swing 擺幅	360° Non-continuous	
Platform Capacity 平台能力	500 lb	227 kg
Platform Size 平台尺寸	27.5x43.3 in	70 x 110 cm
Stowed Height 存放高度	6 ft 6.5 in	1.99 m
Stowed Width 存放寬度	47.2 in	120 cm
Stowed Length 存放長度	14 ft 7 in	4.45 m
Tailswing 尾部擺幅	6 in	15 cm
Wheelbase 軸距	5 ft 3 in	1.6 m
Weight 重量	11,574 lb	5,250 kg
Ground Bearing Pressure	287 psi	20.0 kg/cm ²
Ground Clearance 離地間隙	3 in	8 cm
Battery 電池	24V, 930 amp-hr	
Battery Charger-Output	55 amps	
Brakes 制動器	Spring Applied	

*Specifications Subject to Change Without Prior Notice

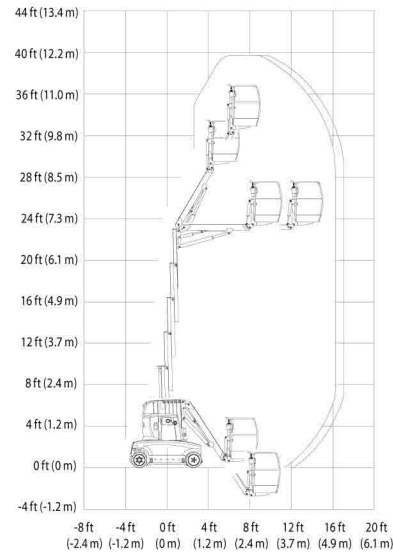

Range Diagram 範圍圖

MLJ33EX

- **Explosion Proof 防爆**
- **Class I, Division 1, Group D** I級, 1區, D組

STANDARD EQUIPMENT 標準設備

- 360° Non-continuous Swing
- 5° Tilt Indicator Light
- Battery Condition Indicator
- Motion Alarm
- Hourmeter
- Lifting Eyes
- Tie-down Lugs

OPTIONS 選項

- ½ in. Airline to Platform
- Motion Alarm