

Planetary Standard Build Winches

The standard build SB type winch provides the basis of the solution to many pulling and lifting winch applications. The winch is constructed in the conventional manner with motor, gearbox and drum in line. Capacities can go up to 70 tons of lifting capacity with this range.

Although the name of this winch indicates differently, these winches are very suitable to suit your specific winch application. Many options can be offered on these highly versatile winches.

標準捲揚機特性

Standard winch features

- Heavy duty planetary gearbox
- SB E; IP 54 400 V AC / 3-phases / 50 Hz braked motor
- SB H; orbit or radial piston type hydraulic motor complete with brake valve
- SB LPR; radial piston type air motor complete with hand control valve and mufflers
- SB LG; gear type air motor complete with hand or remote control valve and mufflers
- Steel drum with cable fixing point at flange
- Two drum supports
- Double layer 2-component conservation according ISO 12944 category C2-Low, colour RAL 5010
- FEM / ISO class: T3-L3-M4

- Alternative supply voltages
- Drum guards
- Spooling gears
- Grooved drums
- Manual emergency crank
- Slip ring mounting
- Alternative drum dimensions / split drums / additional rope anchors / etc.
- Warping head
- Marine / offshore coating systems

可用的控制選項

Available control options

- Control box IP 55 with push-buttons and emergency stop built acc. to NEN 1010
- Control box IP 66 with low-voltage IP 65 remote control built acc. to NEN 1010
- Load limiter (required by CE for applications exceeding 1000 kg WLL)
- Frequency inverter for variable speed control
- Wireless radio remote control systems
- Limit switches (electric, pneumatic)
- Slack wire switches (electric, pneumatic)
- Proportional local or remote control valve (pneumatic or hydraulic)

可用的捲揚機選項

Available winch options

- IP 56 TENV cast iron motor for marine applications
- Explosion-proof motors
- Protective steel motor cover
- Drum pressure roller
- Band brakes (manual or fail-safe automatic)
- Manual disengaging clutch
- Alternative speeds

電動捲揚機 Winch type Electric	WLL 1 st layer kg	WLL 5 th layer kg	Recomm. rope diam. mm	Speed 1 st layer m/min.	Speed 5 th layer m/min.	Drumcap. 1 st layer m	Drumcap. 5 th layer m	Motor power kW
SB 300 E	1200	845	10	9,5	14	26	168	2.2
SB 301 E	2100	1435	12	7	10	24	157	3
SB 303 E	2500	1740	14	11	16	26	165	5.5
SB 304 E	3100	2160	14	9	13	26	165	5.5
SB 305 E	4000	2770	16	7	10.5	25	161	5.5
SB 306 E	5500	3970	18	7	10	28	181	7.5
SB 307 E	7000	4960	22	12	17	26	171	15
SB 309 E	9000	6285	26	14	19.5	24	163	22
SB 310 E	12000	8460	28	8	12	24	168	18.5
SB 311 E	16000	10655	34	7	11	19	144	22
SB 313 E	20000	13610	38	6	8.5	19	151	22
SB 314 E	24000	16170	40	6.5	9.5	19	154	30
SB 315 E	30500	20800	44	6	9	19	151	37
SB 316 E	37000	24570	48	6	9	17	141	45

液壓捲揚機 Winch type Hydraulic	WLL 1 st layer kg	WLL 5 th layer kg	Recomm. rope diam. mm	Speed 1 st layer m/min	Speed 5 th layer m/min	Drumcap. 1 st layer m	Drumcap. 5 th layer m	Pressure drop in bar	Flow in l/min.
SB 303 H	2500	1740	14	18	26	26	165	140	60
SB 304 H	3100	2160	14	15	21	26	165	140	60
SB 305 H	4000	2770	16	18	26	25	161	190	70
SB 306 H	5500	3970	18	25	35	28	181	225	95
SB 307 H	7000	4960	22	20	28	26	171	230	100
SB 309 H	9000	6285	26	13	18	24	163	190	100
SB 310 H	12000	8460	28	11	16	24	168	230	95
SB 311 H	16000	10655	34	10	15	19	144	230	110
SB 313 H	20000	13610	38	8	12	19	151	210	120
SB 314 H	24000	16170	40	8	11	19	154	240	120
SB 315 H	30500	20800	44	8	12	19	151	235	165
SB 316 H	37000	24570	48	6	9	17	141	225	160

氣動活塞捲揚機 Winch type Pneumatic Piston motor	WLL 1 st layer kg	WLL 5 th layer kg	Recomm. Rope diam. mm	Average Speed* m/min.	Maximum Speed** m/min.	Drumcap. 1 st layer m	Drumcap. 5 th layer m	Pressure drop in bar	Flow in l/sec.
SB 300 LPR2	1200	845	10	13	18	26	168	7	90
SB 301 LPR2	2100	1435	12	8	12	24	157	7	90
SB 303 LPR2	2500	1740	14	7	10	26	165	7	90
SB 303 LPR3	2500	1740	14	15	26	26	165	7	140
SB 304 LPR3	3100	2160	14	13	19	26	165	7	140
SB 305 LPR3	4000	2770	16	11	17	25	161	7	140
SB 305 LPR4	4000	2770	16	18	24	25	161	7	240
SB 306 LPR4	5500	3970	18	12	15	28	181	7	240
SB 307 LPR4	7000	4960	22	10	13	26	171	7	240
SB 309 LPR4	9000	6285	26	8	12	24	163	7	240

氣動齒輪捲揚機 Winch type Pneumatic Gear motor	WLL 1 st layer kg	WLL 5 th layer kg	Recomm. Rope diam. mm	Average Speed* m/min.	Maximum Speed** m/min.	Drumcap. 1 st layer m	Drumcap. 5 th layer m	Pressure drop in bar	Flow in l/sec.
SB 300 GP4	1200	845	10	18	23	26	168	7	100
SB 301 GP4	2100	1435	12	10	15	24	157	7	100
SB 303 GP4	2500	1740	14	8,5	11	26	165	7	100
SB 304 GP10	3100	2160	14	22	42	26	165	7	300
SB 305 GP10	4000	2770	16	17	33	25	161	7	300
SB 306 GP10	5500	3970	18	12	23	28	181	7	300
SB 307 GP10	7000	4960	22	10	18	26	171	7	300
SB 307 GP16	7000	4960	22	15	23	26	171	7	350
SB 309 GP10	9000	6285	26	7	13	24	163	7	300
SB 309 GP16	9000	6285	26	11	18	24	163	7	350
SB 310 GP16	12000	8460	28	8	13	24	168	7	350
SB 311 GP16	16000	10655	34	6	10	19	144	7	350
SB 313 GP16	20000	13610	38	5	8	19	151	7	350

* Average speed is based on the speed in the middle layer at 75% of W.L.L.

** Maximum speed is based on the speed in the top layer at unloaded conditions

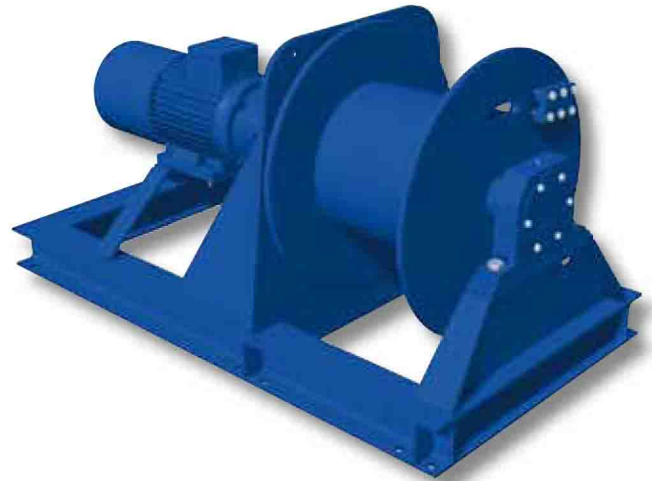
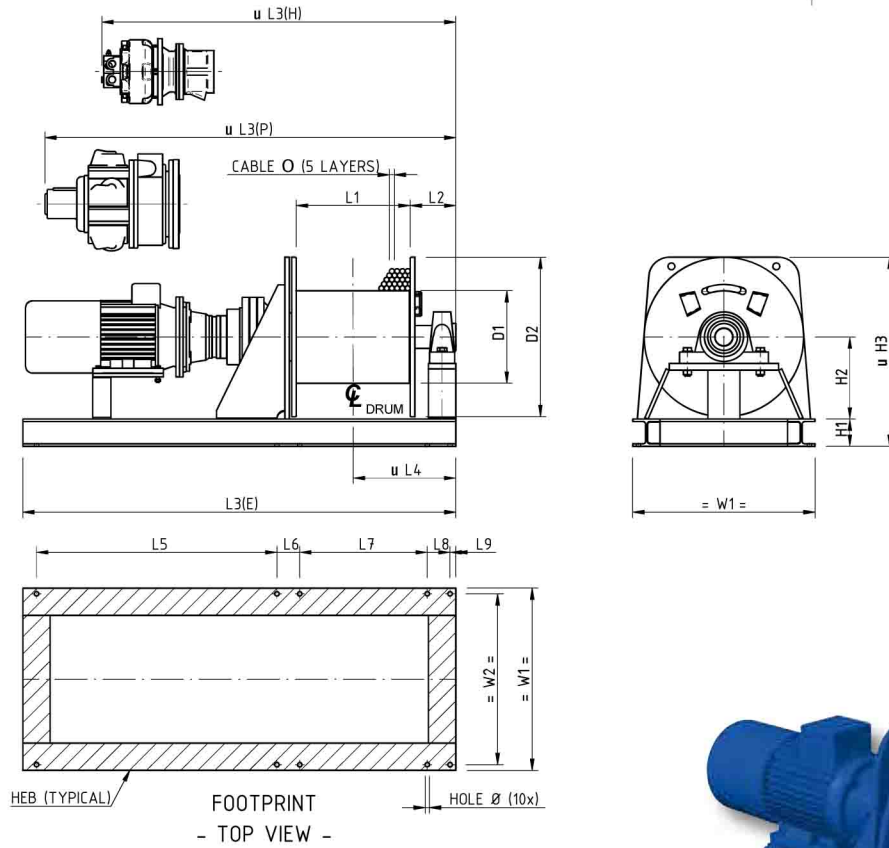

捲揚機型 Winch type	Mass (kg)	D1	D2	L1	L2	L3(E)	L3(H)	L3(P)	L4	L6	L7	L8	L9	H1	H2	H3	W1	W2	Heb	Hole Ø
300	260	178	410	500	135	1400	-	1450	385	80	530	80	20	100	215	520	500	460	100	14
301	270	195	410	500	140	1400	-	1450	390	80	530	80	20	100	215	520	500	460	100	14
303	390	244	500	500	145	1650	1350	1650	395	80	540	80	20	100	260	610	600	560	100	14
304	405	244	500	500	145	1650	1350	1800	395	80	540	550	20	100	260	610	600	560	100	14
305	410	272	500	500	155	1700	1350	1800	405	80	550	80	20	100	260	610	600	560	100	14
306	525	355	600	500	155	1700	1450	1850	405	80	550	80	20	100	310	710	700	660	100	18
307	825	406	700	500	200	1950	1550	1900	450	100	560	100	25	120	360	830	800	750	120	20
309	1215	455	850	500	230	2100	1550	1900	480	110	580	110	30	140	435	1000	1000	940	140	22
310	1470	508	900	500	230	2100	1600	1950	480	120	550	120	40	160	460	1070	1100	1040	160	26
311	1690	508	1000	500	245	2150	1600	1950	495	120	570	120	40	160	510	1170	1150	1090	160	30
313	2270	610	1150	500	265	2250	1700	1950	515	120	600	120	40	180	585	1340	1350	1280	180	33
314	3200	660	1250	500	265	2500	2000	-	515	140	600	550	40	200	635	1460	1450	1370	200	39
315	3550	711	1350	500	300	2650	2050	-	550	140	610	140	40	200	685	1560	1550	1470	200	39
316	3865	711	1400	500	305	2700	2100	-	565	140	615	140	40	200	710	1610	1600	1520	200	39

SB 303 EDGP

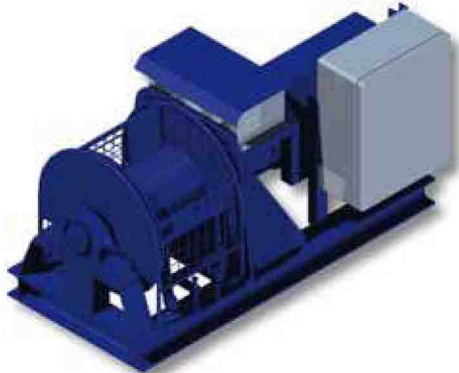

SB 303 EDGP INCLUDING DRUM GUARD, GROOVED DRUM ,
PRESSURE ROLLER, RAINCOVER OVER MOTOR,
AND CONTROL PANEL WITH FREQUENCY INVERTER

SB 311 R EDPS



SB 311 R EDPS INCLUDING RIGHT ANGLE GEARBOX, DRUM
GUARD, PROTECTIVE FRAME AROUND MOTOR, SPOOLING
GEAR AND COUNTER FOUNDATION FOR DECK WELDING

SB 310 H

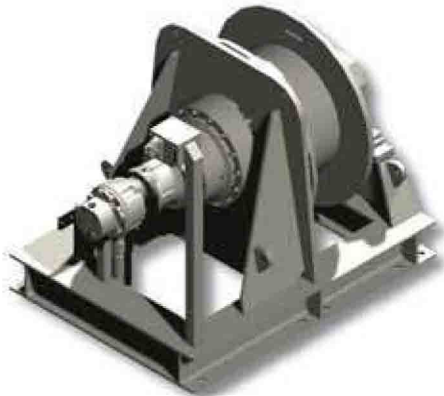

SB 310 H INCLUDING PROPORTIONAL CONTROL VALVE
AND FILTER UNIT

SB 310 HDPS

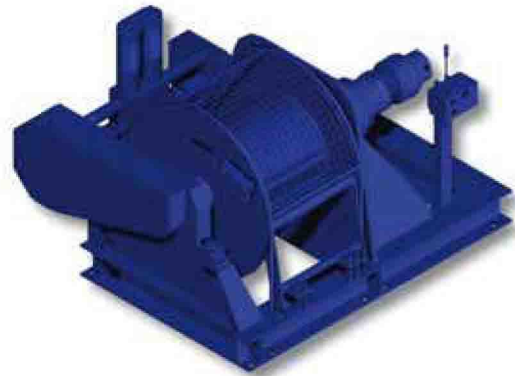

SB 310 HDPS INCLUDING DRUM GUARD, PRESSURE ROLLER,
SPOOLING GEAR AND PROPORTIONAL CONTROL VALVE

SB 306 GP16P



SB 306 GP16P INCLUDING PRESSURE ROLLER, AIR SERVICE
UNIT AND OFFSHORE FRAME